



MAXIGARD™



TACHOMETERS

B1000: ANALOG DISPLAY

(SPEED RANGE: 25 - 3,000 RPM)

B2000: DIGITAL OR ANALOG DISPLAY

(SPEED RANGE: 15 - 7,500 RPM)

B3000: DIGITAL OR ANALOG DISPLAY

(SPEED RANGE: 0 - 5, 0 - 7,500, 0 - 20,000 RPM)

23 MODELS: PROVIDE RANGES FOR ALL APPLICATIONS, SIMPLE FIELD CALIBRATION; RPM, GPM, FPM, ETC

DIGITAL PANEL METERS, .5" LED DISPLAY, SINGLE OR DUAL SET POINT SYSTEMS



ADVANTAGES:

- "Altra-Gap™" sensor system operates in dirt, dust, water, chemicals and magnetic partical environments with accuracy and durability.
- Calibration doesn't change even with large gap changes 1/8" to 7/8" while running.
- High visibility digital display.
- Continuous on-site monitoring of variable speed equipment.
- Remotely mounted system to monitor distant unseen equipment.
- By monitoring the driven shaft the user has an accurate reading of actual machine velocity.
- A complete system

APPLICATIONS:

- Control variable speed drives
- Volume measurement - GPM, RPM, FPM, etc
- Measure pump speed & volume
- Visual display of driven shaft speed
- Continuous oven conveyors
- Maintain proper speed of feed rolls of blenders and mixers

EACH SWITCH INCLUDES AS STANDARD:

Magnet Disc ● Sensing Head with Mounting Bracket, 10' Cable ● Calibration Circuit and Display Meter (Enclosure Optional)

MAXIGARD™ TACHOMETERS

SPECIFICATIONS:

POWER REQUIREMENTS:

B1000: NONE REQUIRED, SELF GENERATED

B2000: 115 VAC, 50/60 HZ

B3000: 115 VAC, 50/60 HZ

ENVIRONMENTAL TEMPERATURE

INFLUENCE: .1% OVER 50°F

OPERATING TEMPERATURE:

-40°F TO + 185°F

FUNCTIONAL:

SENSOR OUTPUT:

B1000, B2000: 0-3 VAC @ 0-4.5 MILLI-AMPS, CURRENT LIMITED

B3000: HALL EFFECT, 6/16 VDC

SENSING DISTANCE:

B1000, B2000: UP TO 10,000 FT

SENSOR TO CALIBRATION CIRCUIT

B3000: UP TO 1,000 FT SENSOR TO

CALIBRATION CIRCUIT

OPERATIONAL SPEED RANGE:

B1000: 25-3,000 RPM, MAX

B2000: 15-7,500 RPM, MAX

B3000: 0-5 RPM OR 0-7,500/20,000

RPM, VERY LOW SPEEDS OR VERY HIGH SPEEDS

METER SCALING:

ANALOG: 50 GRADUATIONS ON METER FACE, SCALE RPM, FPM, GPM, ETC. CUSTOMER SPECIFY

DIGITAL: 0-1999 (3 1/2 DIGIT) OR 0-19,999 (4 1/2 DIGIT), .5" LED DISPLAY, MOVABLE DECIMAL POINT. FIELD CALIBRATION TO REQUIRED ENGINEERING UNIT

CALIBRATION: SEPARATE CALIBRATION CIRCUIT BOARDS

B1000, B2000: ADJUSTMENT BY (15) TURN POT

B3000: TIME BASE ADJUSTMENT BY DIP SWITCHES (SAMPLE AND HOLD) ADJUSTMENT FROM .13 SECONDS TO 29 SECONDS UPDATE

ACCURACY: ± 2%, OF FULL SCALE LINEAR INDICATION, DIGITAL ± 1 DIGIT

REPEATABILITY: ± .5%, FULL SCALE

CONSTRUCTION:

MAGNET DISC: ANODIZED ALUMINUM, CERAMIC MAGNETS

MAGNET WRAP: (OPTIONAL) MACHINED ALUMINUM, BORED TO FIT SHAFT DIAMETER, CERAMIC MAGNETS*

SENSOR PICK UP: ANODIZED ALUMINUM, EPOXY ENCAPSULATED

MOUNTING BRACKET: ANODIZED ALUMINUM

SENSOR CABLE:

B1000, B2000: 22 GAUGE, 2 WIRE SHIELDED "BELDEN" #8761 OR EQUAL

B3000: 22 GAUGE, 3 WIRE SHIELDED "BELDEN" #8771 OR EQUAL

CIRCUITS: P.C. CIRCUIT BOARDS, HEAVY DUTY INDUSTRIAL DESIGN, SOLID STATE COMPONENTS

OPTIONS:

- EXPLOSION PROOF SENSING HEADS
- MAGNET WRAPS *
- ENCLOSURE
- SET POINT
- 4/20 mA OR 0-10 VDC OUTPUTS
- SPECIAL TACHOMETER SCALING

RELATED BULLETINS:

INSTALLATION AND OPERATING INSTRUCTIONS:

- B1000: B124
- B2000: B133
- B3000: B152
- FULL LINE CATALOG: A129

ORDERING INFORMATION:

- CALL OUT OPTIONS AND SPEED RANGE
- SPECIFY METER FACE SCALE
- MAGNET DISC OR OPTIONAL WRAP
- ENCLOSURE IF REQUIRED

NOTE:

* CONSULT FACTORY FOR WRAPS THAT WILL BE TURNING FASTER THAN 3000 RPM

Altra-gap™

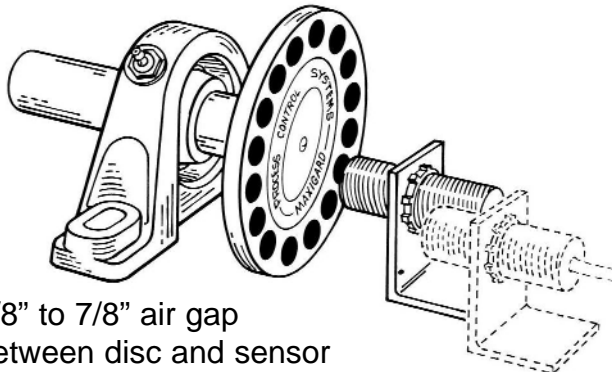

1/8" to 7/8" air gap
between disc and sensor

FEATURES:

- Will work in challenging applications
- Is not affected by material buildup or moisture
- Will work when out of alignment
- Up to 7/8" gap tolerance
- Sensor can be remote mounted up to 10,000 ft.
- Will work in applications with vibration
- Designed for industrial applications

SOLD BY:

327 Lake Hazeltine Drive
Chaska, MN 55318
Toll Free: 800-328-0738 U.S. and Canada
Fax: 952-368-4129
<http://www.maxigard.com>
E-Mail: sales@maxigard.com

