



PROCESS CONTROL SYSTEMS, INC.
327 LAKE HAZELTINE DRIVE, CHASKA, MN 55318

952-361-3026
(Fax) 952-368-4129
800-328-0738

MAXIGARD™



A3000

SLOW SPEED MOTION SWITCH

Introduction

The MAXIGARD A3000 is a fail safe device designed to monitor the rotation of any critical slow driven shaft. The switch can be adjusted to indicate true zero speed or a slow down of the monitored shaft. The A3000 is precision built of quality material and completely factory tested to insure long life and trouble free operation.

Principle of Operation

When the shaft (with magnet disc or optional magnet wrap attached) is rotating, magnets pass in front of the sensing head, causing digital pulses to be generated. These pulses are sent to the switch circuitry resetting an electronic timer, (this is called the Timing Cycle). If a magnet does not pass in front of the sensing head within an adjustable preset time period, the timing circuit will time out and cause the relay to de-energize, thus signaling that a shaft slow down or stoppage has occurred.

The switch has automatic resetting, so if the monitored shaft starts to rotate and it's speed rises above the preset time cycle, the relay will energize and allow the machine or process to restart. However, in some instances, it is desirable that the relay remain de-energized, and the switch remain in the alarm condition, the relay circuit can be modified to perform a latching function. Latching will require a manual reset.

Components

THE A3000 MOTION SWITCH INCLUDES:

- 4" MAGNET DISC
(OTHER OPTIONAL TARGETS AVAILABLE)
- SENSING HEAD W/10' CABLE
- MOUNTING BRACKET
- MOTION SWITCH W/DPDT RELAY
- NEMA 4, UL/CSA LISTED ENCLOSURE

CALL TOLL FREE  800-328-0738

www.maxigard.com
E-mail: techsupport@maxigard.com

SECTION 1 - MECHANICAL

1.0 Magnet Disc

- 1.1 The end of the shaft to be monitored should be square to prevent excessive disc wobble.
- 1.2 Center drill and tap the shaft end. (Suggested #21 drill and #10-32NF tap). Bolt the magnet disc to the end of the shaft. Use "Loc-tite" to keep the bolt and disc tight on the shaft.
(see figure 1A, page 3).

2.0 Magnet Wrap (optional)

- 2.1 Separate the two halves of the magnet wrap by loosening the cap screws holding the two halves together.
- 2.2 Place both halves of the magnet wrap around the shaft. Re-insert and tighten the cap screws making sure the wrap is square to the shaft.
(see figure 1B, page 3).

NOTE

There will be a slight gap between the two halves after tightening. This gap will not affect the generated signal.

3.0 Mounting the Sensing Head

- 3.1 Place the sensing head so that the sensor face is centered directly in front of the magnets in the disc or optional wrap.
(see figure 1A & 1B, page 3)
- 3.2 The gap setting between the sensor and magnet disc should be approximately 1/4" - 3/8".

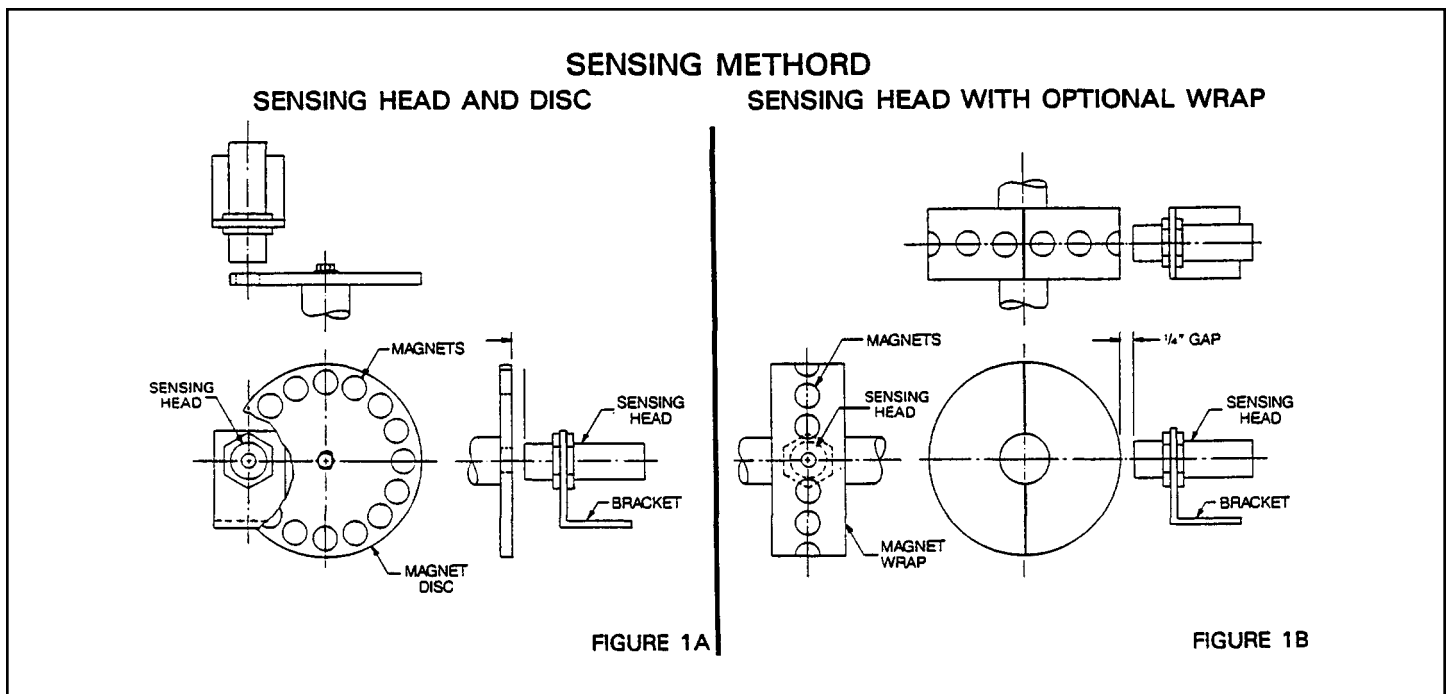

NOTE

The generated signal is not affected by dust, moisture, or build up of any foreign material on the sensing head or magnet disc or wrap.

4.0 Motion Switch Enclosure

- 4.1 A3000 enclosure is UL/CSA listed, rated Nema 4, is dust tight, oil tight, and water tight, steel construction, suitable for indoor and outdoor use.
(see figure 2, page 6)

CAUTION

Remove the circuit board from the enclosure before punching or drilling conduit holes. Be sure to remove all metal chips or fillings, failure to do so could result in damage to the circuit boards.

SECTION 2 - FIELD WIRING

5.0 Wiring and Energizing

5.1 Sensing Head Wiring

5.1.1 Connect the sensing head cable to terminal block TB1, located on the Power Supply circuit board.
(see figure 4, page 5)

5.1.2 The sensing head comes standard with 10' of cable, additional cable can be added as required, be sure to maintain continuity, and wrap the splice with the foil shield and firmly wrap with electrical tape.

SENSING HEAD CABLE

Use "Belden" #8771 or equal. Cable should not be run in same conduit as power lines. Maximum distance of cable run is 1,000 ft. Make good splice connections and check continuity.

6.0 Energizing the Motion Switch through the Motor Starter

WARNING

To avoid electrical shock, disconnect all sources of power to the motor starter before wiring and observe voltage ratings of the motion switch.

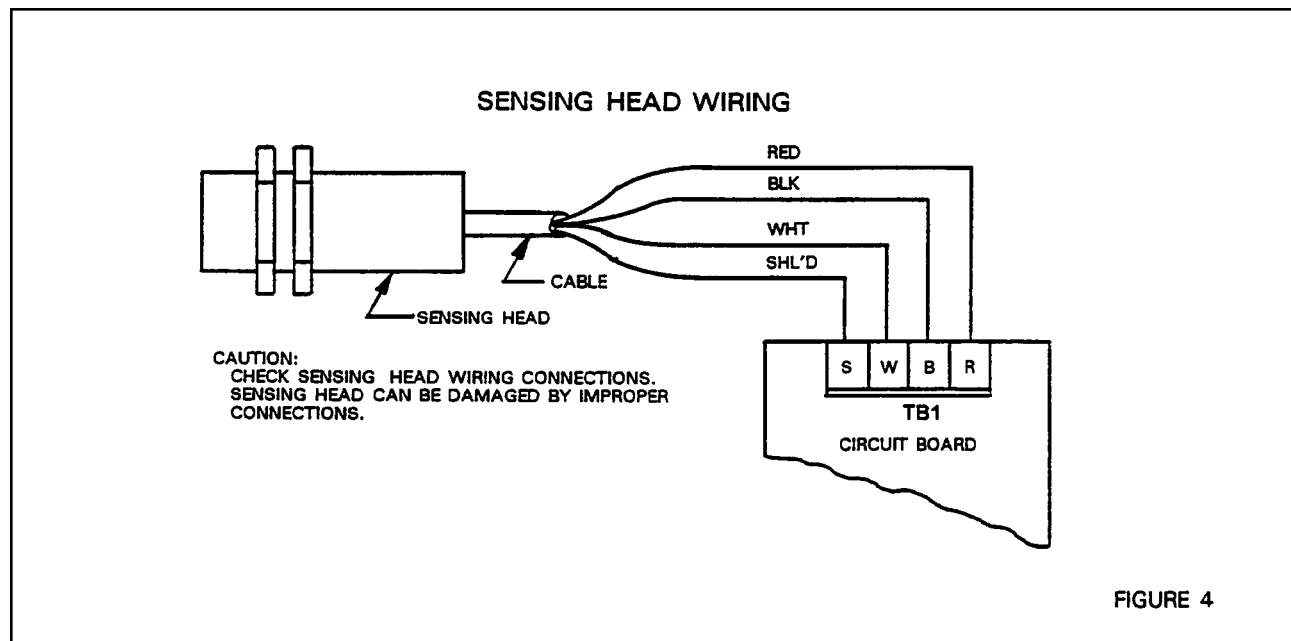

- 6.1** Wire 115 VAC through the motor auxiliary contacts and make proper connections to terminals L1 & L2 on terminal block TB2, located on motion switch Power Supply circuit board.
(see figure 5, page 7)

7.0 Energizing the Motion Switch independent of the Motor Starter

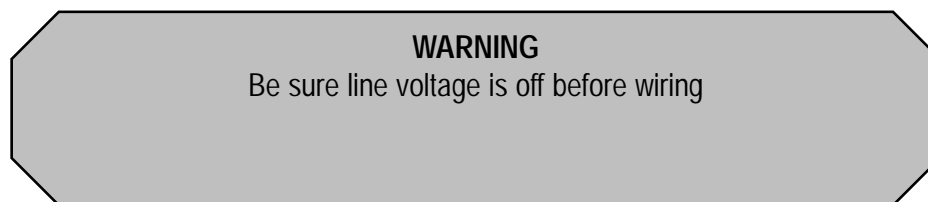

- 7.1** Wire 115 VAC directly to L1 and L2 on terminal block TB2 located on the motion switch Power Supply circuit board.
(see figure 5, page 7)
- 7.2** To avoid electrical noise interference, do not bundle sensing head wire or other low level signal wires with power wires.

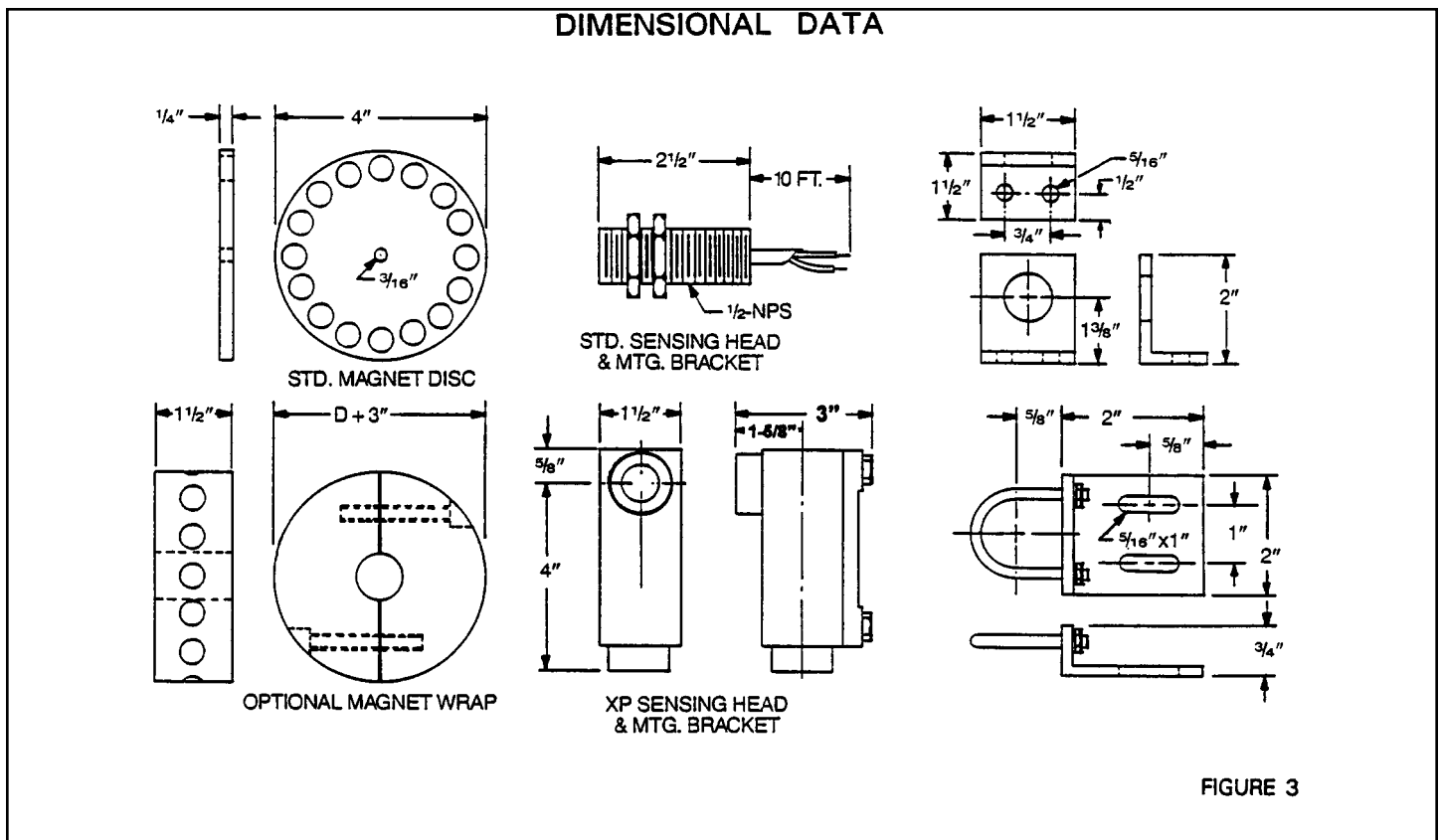
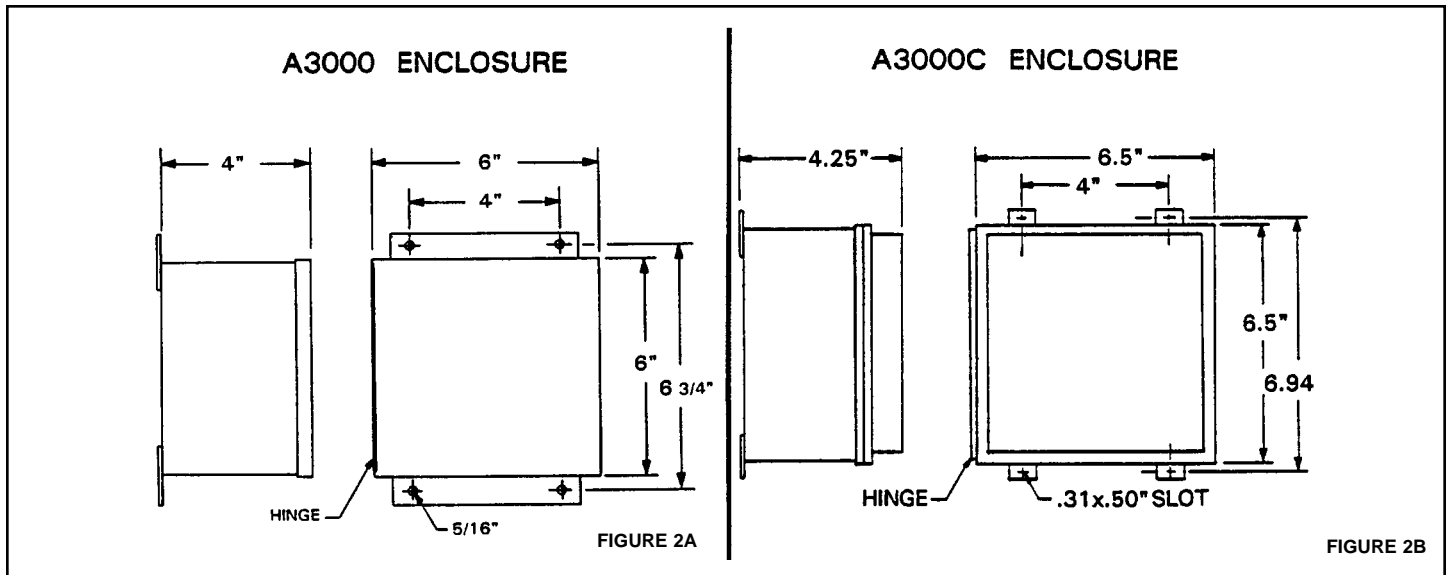

8.0 Calibration and Adjustment

The A3000 motion switch can be adjusted to indicate a slow down, the stopping of, and indicate true zero speed of the monitored shaft.

The Timing Cycle relay is a DPDT - 10 amp - 115 VAC Time Delay Relay, adjustable between .6 - 60 seconds, with a timer adjustment knob located on top of the relay case.

(see figure 5, page 7)

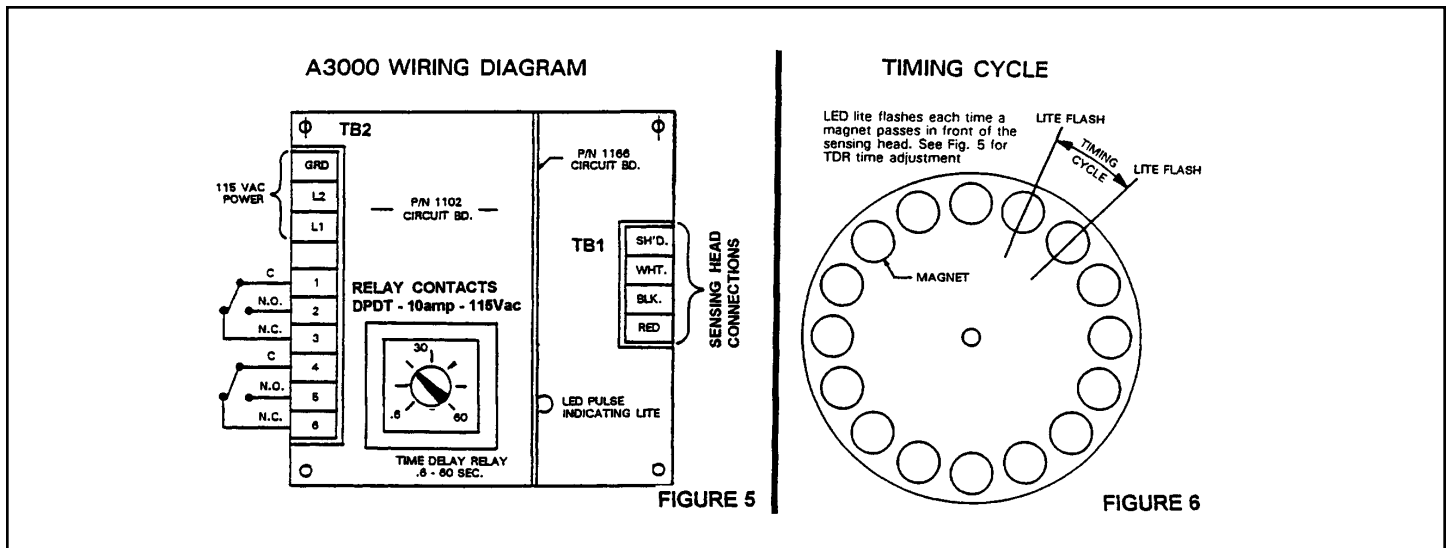

8.1 Timing Cycle Adjustment

The Timing Cycle is the time it takes two magnets in the magnet disc or wrap to pass in front of sensing head.
(see figure 6, page 5)

- 8.1 Apply 115 VAC to the motion switch.

WARNING

Proceed with caution, 115 VAC present and could result in electrical shock.

- 8.2 Locate the green LED light mounted on the plug-in circuit board, P/N 1166.
(see figure 5, page 7)
- 8.3 With power on and the monitored shaft, (with disc or wrap attached) rotating, time the intervals between the flashes of the LED light. These intervals represent the Timing Cycle.
- 8.4 If the relay times out and de-energizes between light flashes, the timer is set to low, turn the knob slightly C.W. to increase the ON time.
- 8.5 If the relay remains energized too long after the shaft stops rotating, the timer is set to high, turn the knob slightly C.C.W. to decrease the ON time.
- 8.6 If an extended time delay is desired to keep the relay energized after the shaft has come to a complete stop, adjust the knob C.W. to increase the ON time. The time delay relay has an adjustment of .6 - 60 seconds.
(see figure 5, page 7)

SPARE PARTS LIST

Part No.	Description
1102	Circuit Board, Power Supply W/O Relay
1166	Circuit Board, Set Point Card
1390	Sensing Head W/10' Cable (Std.)
1130	Mounting Bracket & Jam Nuts (Std.)
1391	Sensing Head W/10' Cable (XP)
1134	Mounting Bracket (XP)
1136	Magnet Disc (4" diameter)
1160	Relay TDR (off) DPDT 10 Amp

LIMITED WARRANTY

Process Control Systems, Inc. will repair or replace, at their option, F.O.B. factory, any part or unit which proves to be defective in material or workmanship within five years of purchase date, provided that part of the unit was installed and operated as recommended, to be established by examination of the part or unit at the factory. Goods returned under warranty must be shipped prepaid to the factory and accompanied by the serial number, description of defect, order number and date of purchase.

This warranty shall not apply to any Maxigard™ product which shall have been repaired or altered outside of the Process Control Systems factory or has been subject to misuse, negligence or accident.

Process Control Systems, Inc. warrants its products, but not their application, and shall not be liable for any incidental or consequential damages incurred through the use or loss of use of a Process Control Systems product. No representatives or other person is authorized or permitted to make any warranty or assume for this company any liability not strictly in accordance with this guarantee.

There is no further warranty either expressed or implied beyond that set forth herein.